

92x92x32mm

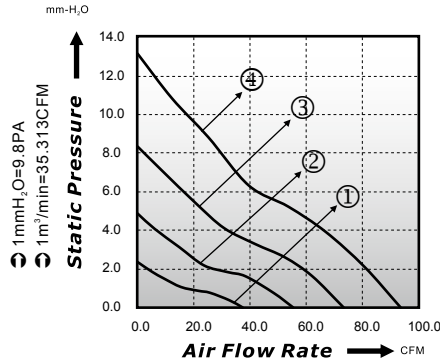

■ P-Q Curve (At Rated Voltage)



■ Dimensions Drawing

Unit: (mm)

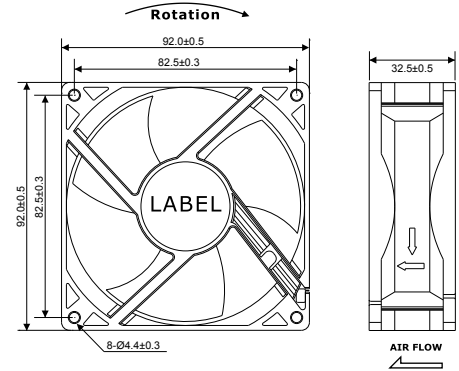

Model No	Bearing (*)	Rated Voltage (VDC)	Rated Current (A)	Power Consumption (Watts)	Speed (rpm)	Air Flow (CFM)	Static Pressure (mmH ₂ O)	Noise (dBA)	Curve
ED09232-12L*	○ ● ⊖	12	0.20	2.40	2000	37.40	2.36	24.00	1
ED09232-12M*	○ ● ⊖	12	0.40	4.80	3000	55.26	4.88	34.10	2
ED09232-12H*	○ ● ⊖	12	0.60	7.20	4000	73.31	8.32	44.70	3
ED09232-12HHB	●	12	0.80	9.60	5000	93.51	13.15	52.10	4
ED09232-24L*	○ ● ⊖	24	0.15	3.60	2000	37.40	2.36	24.00	1
ED09232-24M*	○ ● ⊖	24	0.25	6.00	3000	55.26	4.88	34.10	2
ED09232-24H*	○ ● ⊖	24	0.35	8.40	4000	73.31	8.32	44.70	3
ED09232-24HHB	●	24	0.50	12.00	5000	93.51	13.15	52.10	4

* Bearing Type: ○ Sleeve ● Two Ball ⊖ Hydro-Dynamic